

# PM STEPPING MOTOR MOD.35BY24H01

接线图 COLOURS OF LEAD WIRES

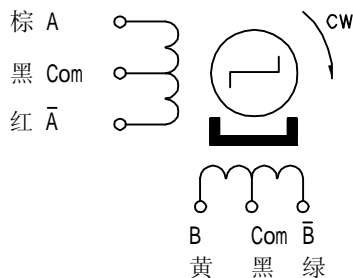

DRIVE MODE:(4-2)

STEP	B	COM	$\bar{B}$	A	COM	$\bar{A}$
1	0	1	X	0	1	X
2	0	1	X	X	1	0
3	X	1	0	X	1	0
4	X	1	0	0	1	X

— CW(SEE FROM THE SHAFT)  
1=Positive Voltage 0=Gnd X=Open

外形图 DIMENSIONS(unit=mm)

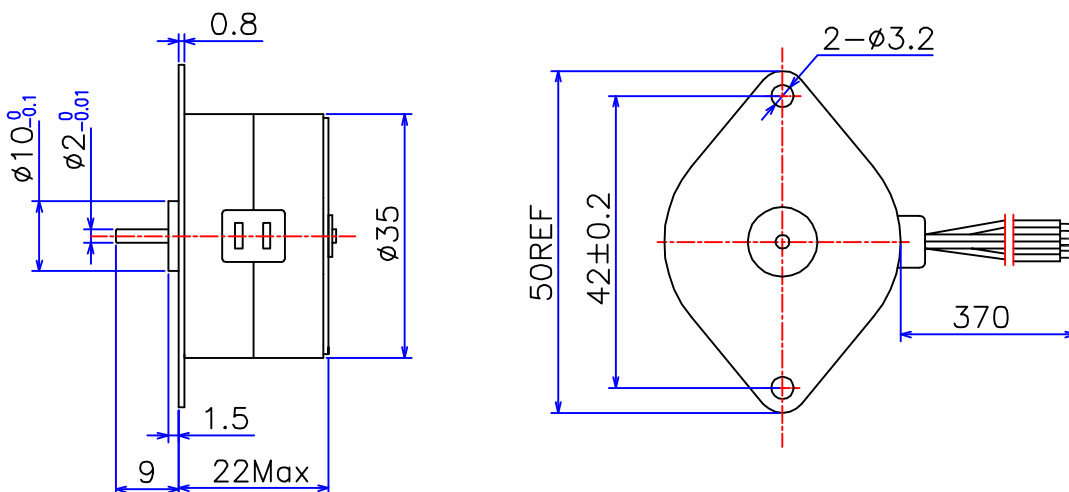

标准规格 Standard Specifications

额定电压	Rated Voltage	24 V	COMMENT
额定电流	Rated Current	0.06 A	
相数	No. of phases	4	
步矩角	Step Angle	15° ±7%	
激磁方式	Excitation	4-2 Unipolar	
使用温度	Operating Temperature Range	-10°C-55°C	
储存温度	Storage Temperature Range	-40°C-70°C	
电阻	Resistance	395 Ω ±7% (20°C)	
保持转矩	Holding Torque	200 g.cm Min	
定位转矩	Detent Torque	90 g.cm Max	
起动转矩	Pull-in Torque	35 g.cm Min (100pps)	
起动频率	Pull-in Rate	200 PPS Min	
转动惯量	Rotor Inertia	4.1 g.cm <sup>2</sup>	
绝缘电阻	Insulation Resistance	100 MΩ (DC 500V) Min	
耐压	Dielectric Withstand Voltage	AC 500V RMS 1min	
重量	Net Weight	90 g	

旧底图总号

底图总号	标记	处数	分区	更改文件号	签名	年.月.日	常州宝来电器有限公司
	设计		091110	标准化			
日期	签名	审核					Tel:0519-88372126 Fax:0519-88372780
		工艺		批准			