

HYBRID STEPPING MOTOR : 57BYGH802A

COLOURS OF LEAD WIRES

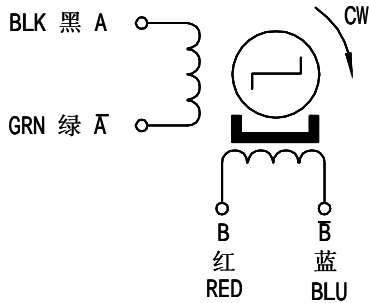

PULSE-TORQUE CHARACTERISTICS

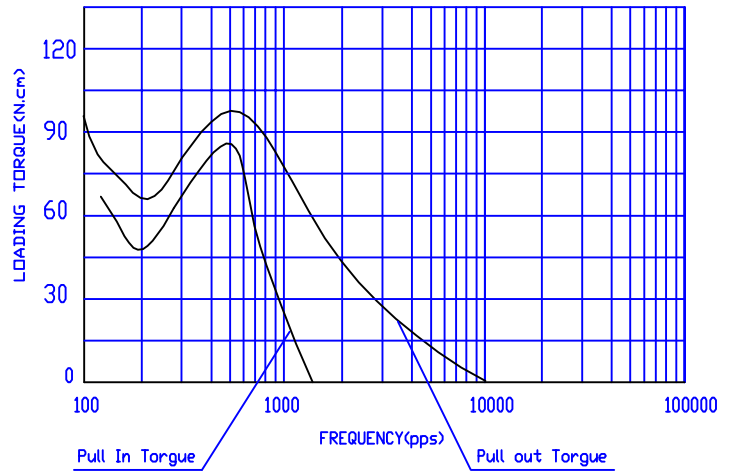

DIMENSIONS (unit=mm)

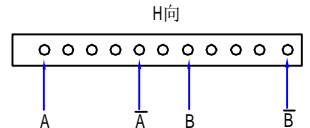
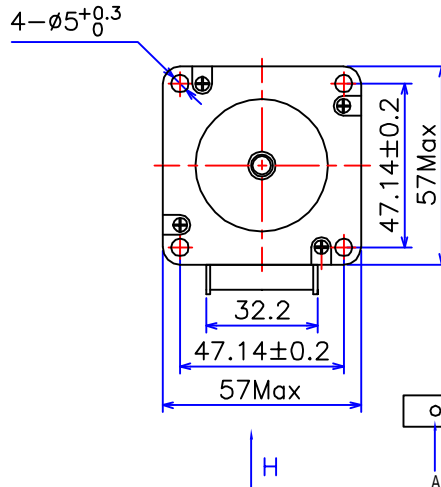
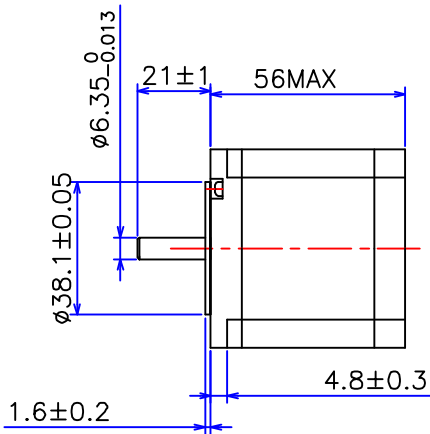

SPECIFICATIONS

Phase	2	COMMENT
Step Angle	1.8 ° ±5%/Step	
Voltage	2.3 V	
Current	2.8 A/Phase	
Resistance	0.8 ±10% ohm/phase	
Inductance	3 ±20% mH/Phase	
Holding Torque	9 Kg.cm	
Detent Torque	0.4 Kg.cm	
Rotor Inertia	280 g.cm ²	
Insulation Class	B	
Weight	0.7 Kg	

旧底图总号

底图总号	标记	处数	分区	更改文件号	签名	年.月.日	常州宝来电器有限公司
	设计		101112	标准化			
日期	签名	审核					Tel:0519-88372126 Fax:0519-88372780
		工艺		批准			

格式 (1)

制图 :

描图 :

幅面: 4[#]